

FEDERAL SUPPLY CLASS  
5306

RATIONALE

REVISE LEAD THREAD CHAMFER REQUIREMENT TO AS1132, GENERAL EDITORIAL AND FORMAT CHANGES THROUGHOUT.

NOTICE

THE INITIAL SAE PUBLICATION OF THIS DOCUMENT WAS TAKEN DIRECTLY FROM U.S. MILITARY STANDARD MS9589D, AMENDMENT 1. THIS SAE STANDARD MAY RETAIN THE SAME PART NUMBERS ESTABLISHED BY THE ORIGINAL MILITARY DOCUMENT.

ANY REQUIREMENTS ASSOCIATED WITH QUALIFIED PRODUCTS LISTS (QPL'S) MAY CONTINUE TO BE MANDATORY FOR DoD CONTRACTS. REQUIREMENTS RELATING TO QPL'S HAVE NOT BEEN ADOPTED BY THE SAE FOR THIS STANDARD AND ARE NOT PART OF THIS SAE DOCUMENT.

REV.  
B

AS9589™

SAE Executive Standards Committee Rules provide that: " This report is published by SAE to advance the state of technical and engineering sciences. The use of this report is entirely voluntary, and its applicability and suitability for any particular use, including any patent infringement arising therefrom, is the sole responsibility of the user." SAE reviews each technical report at least every five years at which time it may be revised, reaffirmed, stabilized, or cancelled. SAE invites your written comments and suggestions.

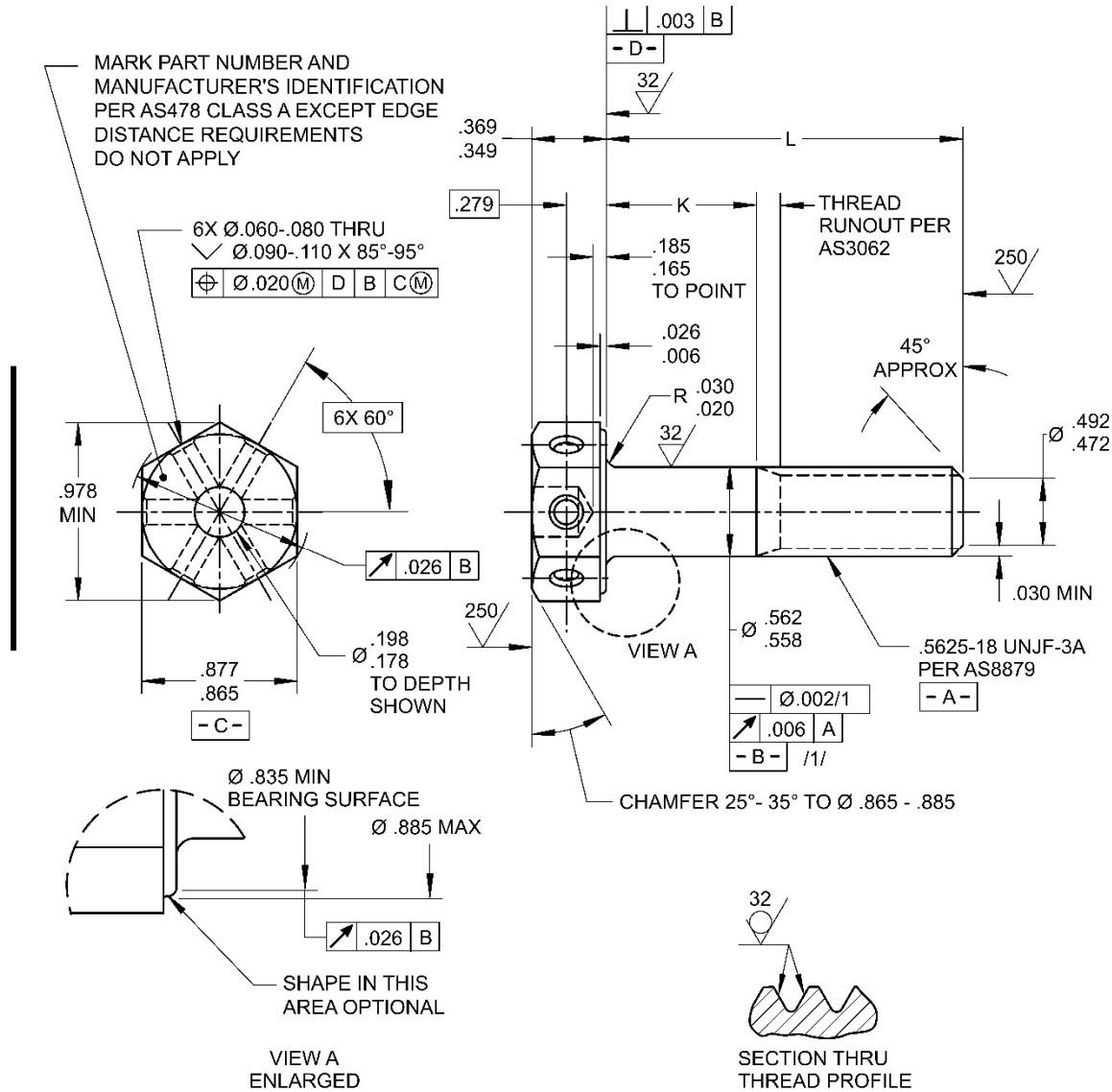
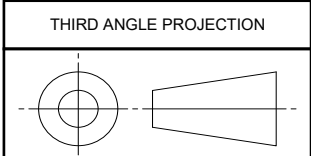

FIGURE 1 - BOLT

For more information on this standard, visit  
<https://www.sae.org/standards/content/AS9589B/>



CUSTODIAN: E-25

PROCUREMENT SPECIFICATION: AS7477



**AEROSPACE STANDARD**

BOLT, MACHINE-HEXAGON HEAD, DRILLED,  
6 HOLES, FULL SHANK, CORROSION AND HEAT  
RESISTANT STEEL (UNS S66286), .5625-18 UNJF-3A

AS9589™  
SHEET 1 OF 3

REV.  
B

ISSUED 1999-04 REAFFIRMED 2006-05 REVISED 2021-04